



Brokerage

NAU
YACHTS

GRAZIADIU

MOTOR YACHT MANGUSTA (OVERMARINE) 33.48M 2008

€2,500,000

FLAG - CAYMAN ISLANDS

MOTOR YACHT

GRAZIADIU



GRAZIADIU is a 33.48-metre **Mangusta 108** motor yacht delivered in 2008 by **Mangusta (Overmarine)**, with a comprehensive refit completed in 2025. She is a high-performance planing yacht designed with a strong focus on speed and dynamic cruising.

Accommodation is arranged for up to 10 guests across four staterooms. The full-beam master suite is located amidships and features a lounge area, desk, and en-suite bathroom. Forward are two VIP cabins with double beds and en-suite facilities. An additional guest cabin offers flexible arrangements, including a single bed, bunk beds, and a Pullman berth. Crew quarters for five are arranged across three cabins with separate service areas.

Powered by twin MTU 12V 4000 M90 diesel engines (2,730 hp each, approx. 1,566 hours), **GRAZIADIU** delivers the high-performance characteristics expected from the **Mangusta** range. Power is supported by twin Kohler generators (33 kW each, 230V AC / 24V DC). Technical equipment includes a Frigomar air conditioning system, a 47 kW hydraulic bow thruster, Racor and Westfalia fuel filtration systems, and Gianneschi pumping and firefighting systems.

The yacht comes with a Williams Turbojet 385 tender, a jet ski, and a selection of water toys, enhancing onboard leisure options.

A significant refit in 2025 included servicing of the main engines, generators, and waterjet systems, maintenance of anchoring equipment, renewal of antifouling coatings, and class inspections. **GRAZIADIU** is compliant with Maritime and Coastguard Agency (MCA) requirements and classed by Bureau Veritas, making her suitable for charter operations.

Combining high-speed performance, solid technical pedigree, and recent upgrades, **GRAZIADIU** represents a compelling option for both private use and charter.

[see more information about M/Y GRAZIADIU at www.nauyachts.com](http://www.nauyachts.com)

SPECIFICATION

SHIPYARD, MODEL	Mangusta (Overmarine) 108
BUILT	2008
LENGTH	33.48 m
WATERLINE LENGTH	28.5 m
HULL CONFIGURATION	PLANING
BEAM	7.1 m
RANGE	460
DRAFT	1.35 m
GROSS TONNAGE	181 GT
YACHT CLASS	BUREAU VERITAS
CABINS	4+3
MASTER CABIN	MAIN DECK
GUESTS	10
BERTHS	10+6
CREW	6
HEADS	4+2

EXTERIOR DESIGN	STEFANO RIGHINI
INTERIOR DESIGN	OVERMARINE
HULL	GRP
SUPERSTRUCTURE	GRP
ENGINES	2 x MTU 16V 2000 M94 2730 h.p.
TYPE OF DRIVE	JET
ENGINE HOURS	1566 h
MAXIMUM SPEED	35 kn
CRUISING SPEED	32 kn
FUEL CONSUMPTION AT ECONOMICAL SPEED	~ 800 l/h
FUEL	14000 l
GREY WATER	350 l
BLACK WATER	300 l
FRESH WATER	2000 l
DISPLACEMENT	110

[see more information about M/Y GRAZIADIU at www.nauyachts.com](http://www.nauyachts.com)



EXTERIOR MANGUSTA 108 2008 MY
GRAZIADIU

M/Y GRAZIADIU



EXTERIOR MANGUSTA 108 2008 MY
GRAZIADIU

M/Y GRAZIADIU



EXTERIOR MANGUSTA 108 2008 MY
GRAZIADIU

M/Y GRAZIADIU



EXTERIOR MANGUSTA 108 2008 MY
GRAZIADIU

M/Y GRAZIADIU



COCKPIT SEATING AREA

M/Y GRAZIADIU



COCKPIT SEATING AREA

M/Y GRAZIADIU



COCKPIT DINING AREA

M/Y GRAZIADIU



MAIN SALON LOUNGE AREA

M/Y GRAZIADIU



MAIN SALON LOUNGE AREA

M/Y GRAZIADIU



MAIN SALON LOUNGE AREA

M/Y GRAZIADIU



MAIN SALON LOUNGE AREA

M/Y GRAZIADIU



MAIN SALON DINING AREA

M/Y GRAZIADIU



MAIN SALON DINING AREA

M/Y GRAZIADIU



MAIN HELM STATION

M/Y GRAZIADIU



MASTER CABIN

M/Y GRAZIADIU



MASTER CABIN

M/Y GRAZIADIU



MASTER CABIN

M/Y GRAZIADIU



MASTER CABIN

M/Y GRAZIADIU



MASTER BATHROOM

M/Y GRAZIADIU



MASTER BATHROOM

M/Y GRAZIADIU



VIP CABIN

M/Y GRAZIADIU



VIP CABIN

M/Y GRAZIADIU



VIP CABIN

M/Y GRAZIADIU



VIP BATHROOM

M/Y GRAZIADIU



VIP CABIN

M/Y GRAZIADIU



VIP CABIN

M/Y GRAZIADIU



VIP BATHROOM

M/Y GRAZIADIU



GUEST CABIN

M/Y GRAZIADIU



GUEST CABIN

M/Y GRAZIADIU



GUEST BATHROOM

M/Y GRAZIADIU



GALLEY

M/Y GRAZIADIU



GALLEY

M/Y GRAZIADIU



CREW CABIN

M/Y GRAZIADIU

General Arrangement

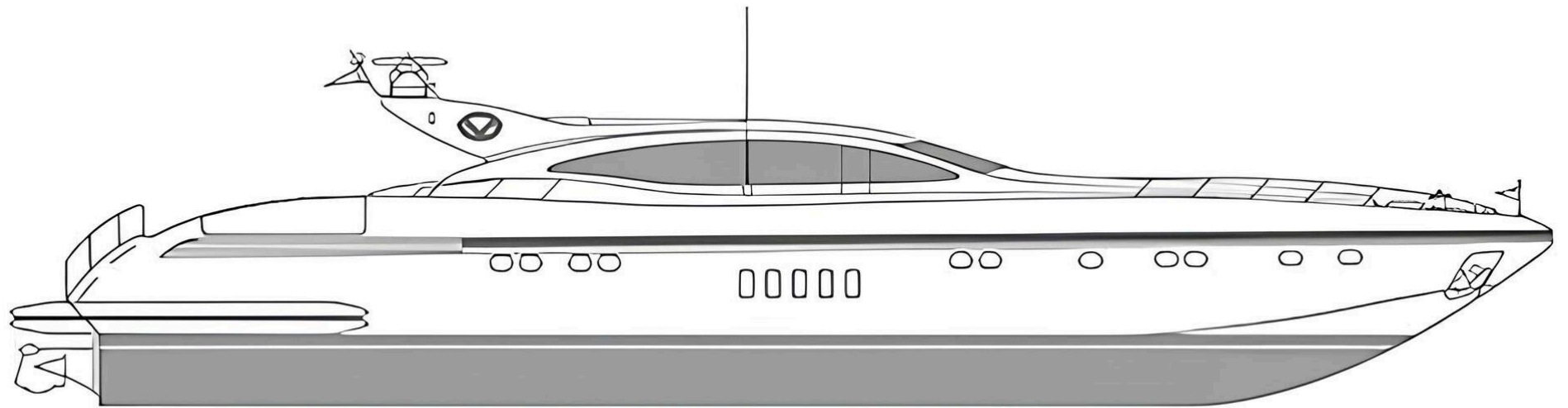

PROFILE



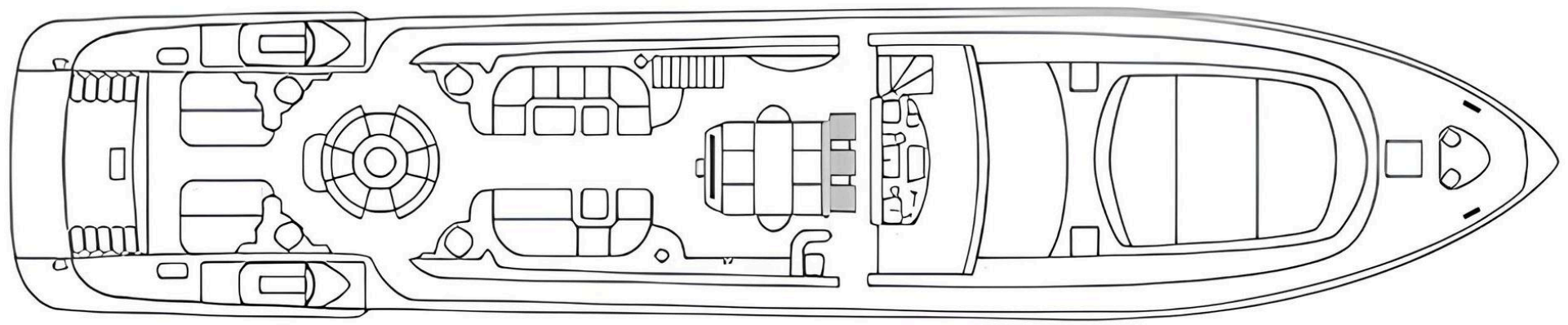

MAIN DECK

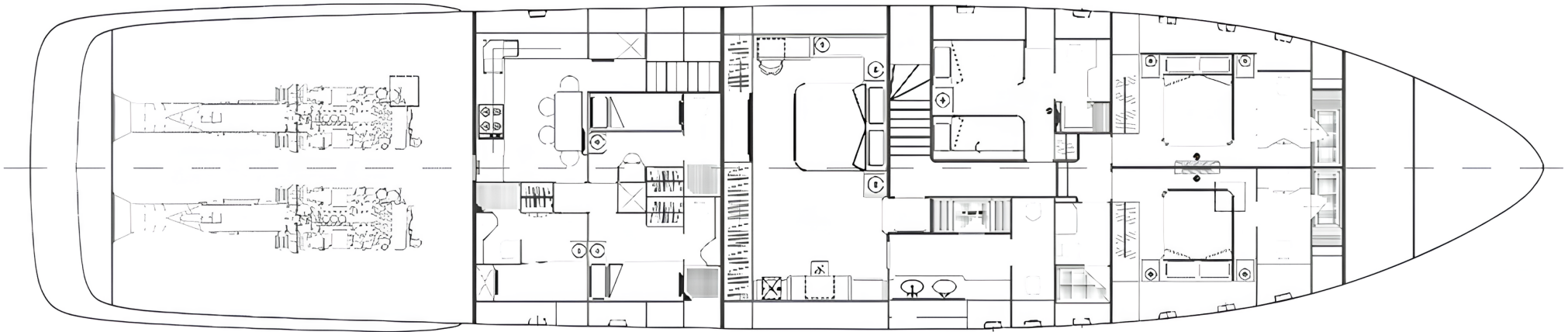

LOWER DECK



KIRILL KUATOV

+377 607 93 15 20

+39 333 576 44 44

[Send e-mail](#)

[WhatsApp](#)

[Telegram](#)